

FREEZER | Countertop Freezers

UPRIGHT FREEZER

RNG 30

CUSTOMIZATION AVAILABLE
PERSONALIZZAZIONE DISPONIBILE



60 mm	L1 -18°C -15°C	C ENERGY CLASS	3 +25°C/60RH
LED			GAS R290

DETAILS

GENERAL FEATURES

- 21 Lt. Upright freezer
- Aluminium for internal and grey coated steel for external side
- Static Cooling
- Manual Defrost
- Foaming Agent Cyclopentane (60mm per side)
- Removable Gasket
- Inner vertical LED light (with independent switch)
- Door: Self closing and heated glass (Not reversable)
- Digital thermometer display
- Painted aluminium door frame with integrated handle
- Lock fitted as standard
- Adjustable shelves: 1 Pcs
- N.4 Adjustable feet
- Energy efficiency class: C

TECHNICAL SPECIFICATIONS

External Dimensions (WxDxH mm)	380x441x534
Internal Dimensions (WxDxH mm)	260x280x370
Noise level	42 dB(A)
Consumption	2.97 kWh/24h
Capacity	30 L
Rated Power	135 W
Net Weight	23 Kg
Temperature	L1 (-15°C--18°C)
Gross Weight	25 Kg
Packaging dimensions (WxDxH mm)	455x517x600
Loading quantities 20'/40'/40'HQ	144/312/416

PRODUCT DIMENSIONS

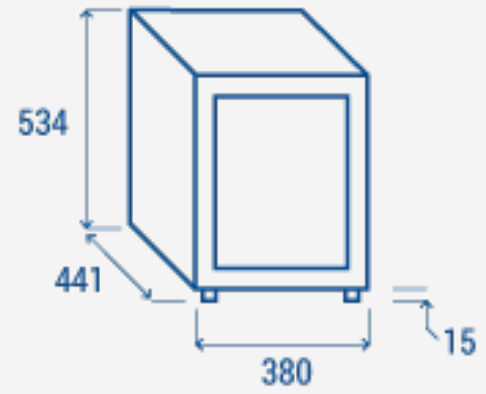

CERTIFICATION

CE RoHS

